

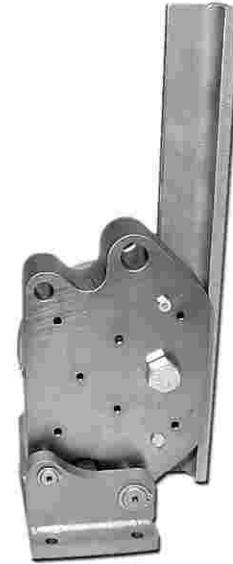

MK Rail/Disc Brake

The Hilliard/Twiflex type MK Rail/Disc Brake is designed for use on elevators, conveyors, cranes, or other devices requiring a spring-applied electromagnetically released brake. The patented MK brake can be applied to a guide rail or a brake disc. It is unique in that it is direct acting with only one moving part. The brake incorporates an electromagnetic coil that uses a voltage dropping circuit to minimize current draw and heat when the brake is released. Shipped with manual release bolts for easy assembly to the rail or disc, it can also be equipped with a manual release mechanism for a momentary release of the brake with a standard open-end or socket wrench.



MK Rail Brake

Benefits

- Designed for holding duty and emergency stopping
- Manual release mechanism automatically reapplies the brake when force is removed
- Equipped with a microswitch for monitoring brake status
- Can be configured for various rail or disc thickness
- Easy to install; equipped with manual release bolts
- Can be adjusted for wear by adding shims behind the brake pads
- Mounted on pins allowing for axial movement

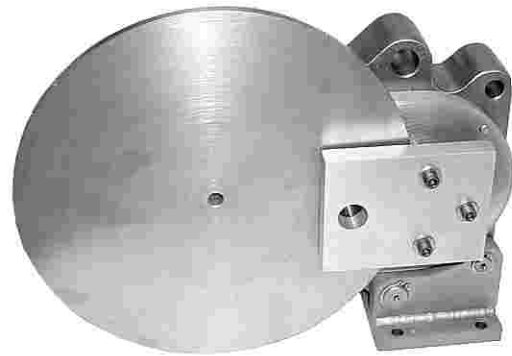

MK Disc Brake

Torque Calculation

Rated Torque = $\frac{\text{Braking Force} \times (\text{Disc Radius} - "X")}{12}$ in Lb-Ft Torque

If the brake is for holding duty and no dynamic stops are made, reduce rated torque by 50%.

Mounting Arrangements

- Base-mounted
- Guide pin mounting



MK Rail/Disc Brake

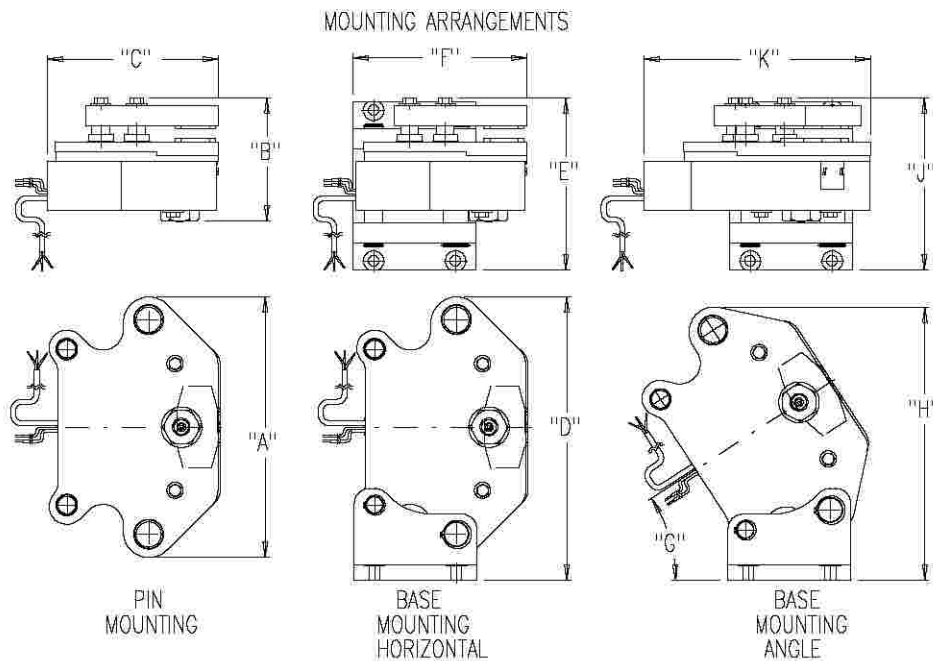

APPROXIMATE ENVELOPE DIMENSIONS (in inches) & WEIGHTS											
TYPE	A	B*	C	D	E*	F	G	H	J*	K	WEIGHT
MK750	12 3/4	6 1/8	8 3/8	13 7/8	8 1/2	8 1/2	33°	13 1/2	8 1/2	11 1/8	50 lbs
MK1400	13 1/2	6 1/2	8 3/4	14 5/8	8 3/4	8 3/4	33°	14	8 3/4	11 5/8	80 lbs
MK4800	21 1/2	9 1/4	14 1/2	23	12 7/8	14 1/2	28°	22 1/2	12 7/8	18 7/8	325 lbs

*Dimension varies with disc thickness

The Hilliard Corporation reserves the right to change specifications at any time. Please contact the factory for the most current information.

DATA					
BRAKE TYPE	MAXIMUM BRAKING FORCE (1)	RELEASE VOLTAGE	HOLDING VOLTAGE	COIL RESISTANCE	DIMENSION "X" (inches)
MK750	1600 LBF	210 VDC	105 VDC	87 OHMS	1.25
MK1400	2500 LBF	210 VDC	105 VDC	82 OHMS	1.38
MK4800	7200 LBF	210 VDC	105 VDC	34 OHMS	2.25

(1) Braking force listed is based on clean, dry and fully bedded friction surfaces. Initial values can be as much as 60% less than the above values.