



DISC BRAKE CALIPER TYPE: VH

HYDRAULICALLY APPLIED—SPRING RELEASED

DB 2015

Issue 2

Date: May 84

See Publication Ref. No. P163 for Installation, Operation and Maintenance.
Technical and Performance Data on reverse side.

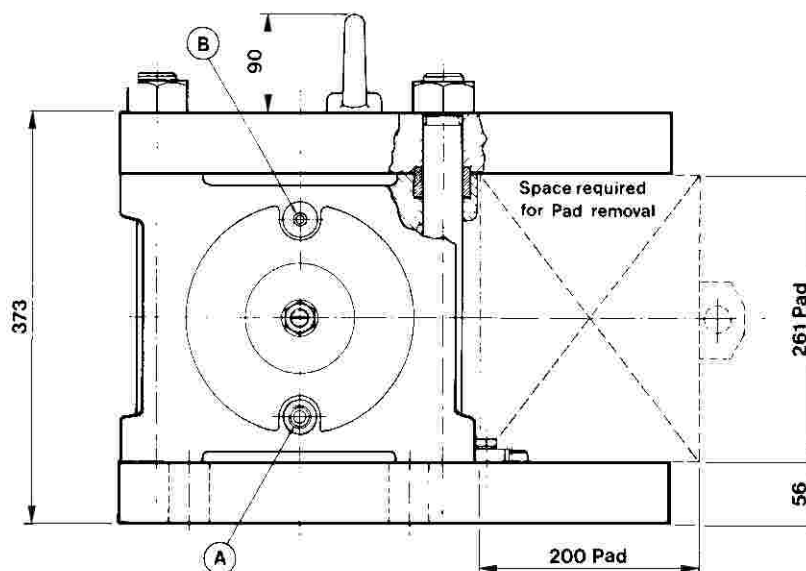
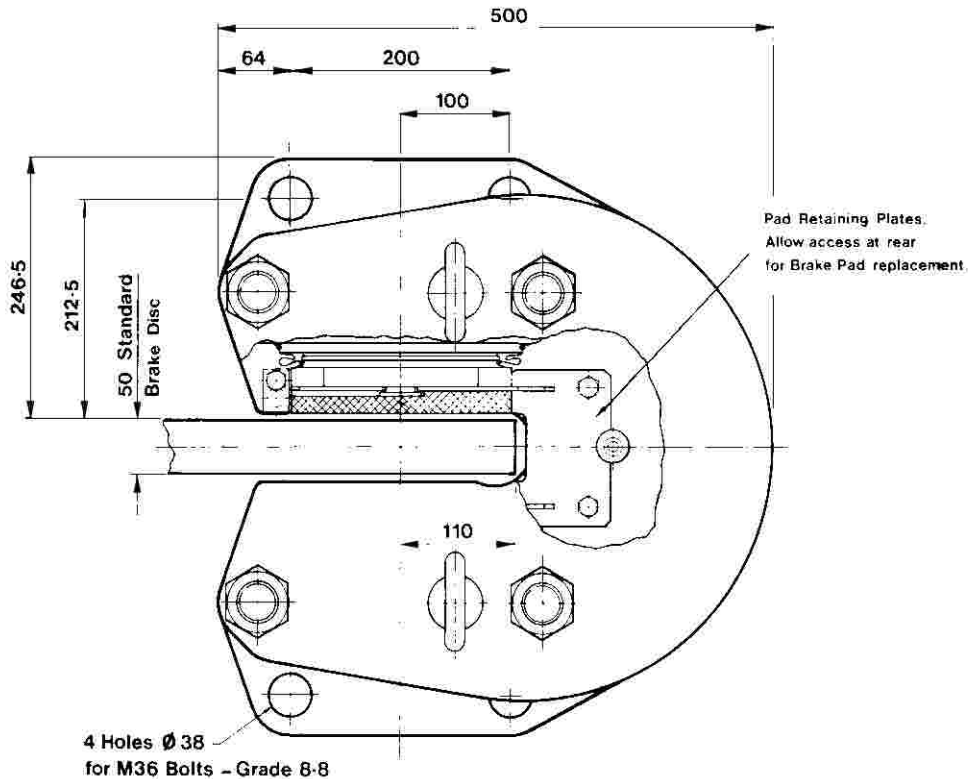

Fittings/Ports:

- (A) Inlet Port — G ½" (½" BSP) 1 each side.*
- (B) Bleed Screw — G ⅛" (⅛" BSP) 1 each side.

* Inlet ports are usually supplied with fittings for Ø 12 × 1.5 mm pipe to DIN 2391C



**DISC BRAKE CALIPER
TYPE: VH**

DB 2015

HYDRAULICALLY APPLIED—SPRING RELEASED

Issue 2

Date: May 84

Technical Data:

- Total friction pad area per caliper — 1039 cm²
- Caliper weight — 287 kg Approx.
- Minimum disc diameter — 800 mm.
- Disc thickness (standard) — 50 mm.*
- Brake pad retraction—adjustable up to 6mm max.
- Brake pad wear allowance — 13mm.
- Total oil displacement for 6mm retraction at each pad — 310 ml.
- Hydraulic fluids — Use with MINERAL BASE HYDRAULIC FLUIDS ONLY.**
- Working pressure — 140 bar (normal)
— 175 bar (maximum)

*Calipers can be designed to accommodate disc (or wheel) thickness from 38 mm upwards.
** Such as Burmah Castrol Hyspin AWS32, Shell Tellus 37 or equivalent.
Correctly formulated water in oil emulsions may also be used.

Performance Data:

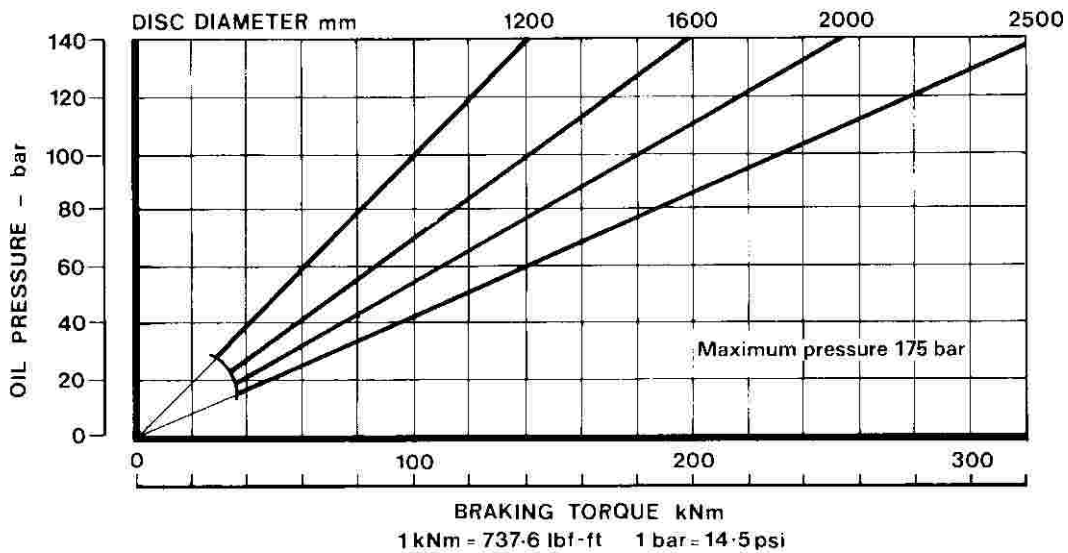

The above braking torque figures are based on a nominal pad friction coefficient $\mu = 0.4$ (Pad Part No. 7950981) and apply to fully bedded-in pads.

Braking Force at 140 bar hydraulic pressure ≈ 285 kN.

Braking Torque (kNm) = Braking Force (kN) \times Effective Disc Radius (m)

where Effective Disc Radius (m) = Actual Disc Radius (m) $- 0.110$

Spares

A spare set of brake pads should be kept in a dry place where there is no chance of oil pollution.

Service

Address all enquiries regarding this equipment to your Twiflex agent or direct to Twiflex Couplings Limited.